



BTS
ENGINEERING

<https://prom-nasos.pro>

<https://bts.net.ua>

<https://prom-nasos.com.ua>

+38 095 656-37-57,

+38 067 360-71-01,

+38 063 362-12-31,

info@prom-nasos.pro

INSTRUCTION MANUAL PERISTALTIC PUMP

TEC-POOL

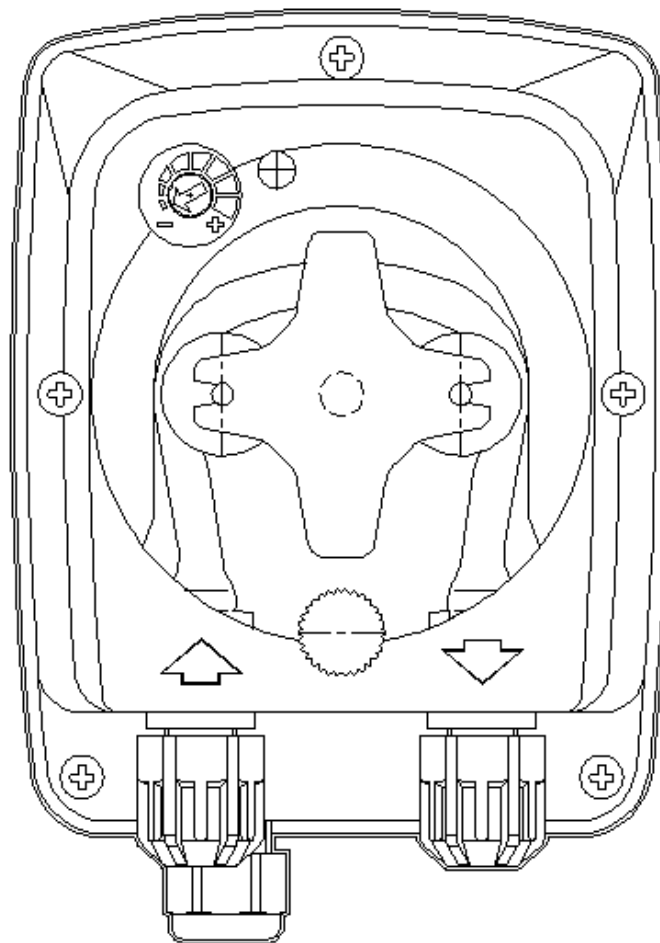

Sommario	
TECHNICAL FEATURES	3
STANDARDS OF REFERENCE	3
BEFORE STARTING	3
WALL MOUNTING	3
ELECTRIC INSTALLATION	3
HYDRAULIC INSTALLATION.....	3
TANK INLET ASSEMBLY (see fig. 1)	3
OPERATION OF THE PUMP (see. fig. 2).....	3
OPERATION OF THE TWO-COLOURED LED	4
OPERATION OF THE SWITCH	4
LEVEL ALARM	4
MOTOR ALARM	4
SWITCH ALARM.....	4
MAINTENANCE (see fig. 3).....	4
PROVIDED KIT OF ACCESSORIES.....	5
FIGURE / FIGURE / FIGURE.....	6

TECHNICAL FEATURES

Power supply: read the label on the pump
 Nominal absorbed power: 4 W; max. 7 W.
 Suction height (max): 1.5 m.
 Capacity and backpressure: read the label on the pump

Before starting the assembly, read carefully these instructions and follow them when installing.



Should the instructions indicated in this manual be not observed or not followed correctly, damages to people, device and/or the system may occur.

STANDARDS OF REFERENCE

Our pumps are manufactured according to General Standards in force and in compliance with the following European Directives:

- n° 2014/30/CE “ E.M.C.
- n° 2014/35/CE “DBT Low Voltage Directive”
- n° 2011/65/UE , 2012/19/UE “direttive RoHs e WEEE”

BEFORE STARTING

It is recommended to read carefully the label located on the pump and verify the following sections:

- The peristaltic tube must be compatible with the liquid to be dosed.
- Power voltage must be compatible with that indicated.
- Pressure in correspondence to the injection section must be lower or equal to the nominal one of the pump.

WALL MOUNTING

Use the provided adhesive label to fix the pump to the wall.

- Apply the label on the wall, where the pump must be placed, and drill holes in the two sections of the adhesive card.
- Fix the bracket to the wall using the provided plugs and screws.
- Place the pump on the bracket.
- Ensure the fixing is stable.



It is also recommended to install the pump in a dry environment, away from heat sources and exhaust vapour.

ELECTRIC INSTALLATION



Before performing any intervention on the pump, disconnect the power supply voltage of the machine.

Connect the cable of the pump at a voltage compatible with the label one, so that there can be an all-pole disconnection device with a contact opening distance of at least 3 mm.

CAUTION !!!!!



Verify that the earth system is perfectly functional and complies with the applicable regulations. Make sure that the highly sensitive differential switch is present (0.03 A). Verify that the rated values of the pump are compatible with those of the mains. Never install the pump directly in parallel with inductive loads (e.g. motors/solenoid valves) if necessary, use an isolating relay. There are 2 protection devices inside the pump: a varistor and a fuse.

HYDRAULIC INSTALLATION

- the suction tube must be located inside the product container and then connected to the pump suction fitting (with ▲ mark on the cover) and tightened with the appropriate ring-nut.
- the delivery tube must be inserted on the pump delivery fitting (with ▼ mark on the cover) and tightened with the appropriate ring-nut; then connect it to the tank inlet fitting or to the injection valve.

TANK INLET ASSEMBLY (see fig. 1)

Mount the injection valve in a threaded socket made on the water delivery pipe, or using a T-collar (optional).

OPERATION OF THE PUMP (see. fig. 2)

The potentiometer allows to adjust the pump speed:

- to the minimum (totally counter clockwise rotated): 10%

- to the maximum (totally clockwise rotated): 100%

Moreover, speed is displayed by modulating the green LED period on the basis of 10 seconds.

OPERATION OF THE TWO-COLOURED LED

The two-coloured Led indicates the various pump operation phases:

- if it is fixed orange, the pump is performing the priming phase.
- if it is flashing green, the pump operates regularly; moreover, the flashing frequency is directly proportional to the speed rotation, in fact:

10% => 5 seconds on and 5 seconds off – in 10 seconds it performs 1 flash (slow)

50% => 1 second on and 1 second off – in 10 seconds it performs 5 flashes

100% => 0.5 seconds on and 0.5 seconds off – in 10 seconds it performs 10 flashes (fast)

- flashing red means the motor is blocked or, in the level probe version, it indicates the exhaustion of the chemical product to be dosed.
- fixed red means the pump is in stand-by, switch positioned on off or the pump is performing the three re-starting attempts of the motor.

OPERATION OF THE SWITCH

Placed on the lower part of the pump, the switch has 3 positions:

I: the pump is active (ON)

The led is flashing green with a frequency proportional to the speed set on the potentiometer.

O: the pump is in stand-by (OFF)

Led is fixed red.

II: the pump is in priming mode (MOM)

Led is fixed orange, the pump works for 60 seconds at the maximum speed. If the button is pressed again before the 60 seconds, the pump goes in stand-by or in normal operation, depending on the position of the switch.



LEVEL ALARM

A level probe can be connected to the pump to signal the end of the product, which is indicated by the pump in the following way:

- Acoustic signal through the buzzer (if installed on the pump), with a frequency of 1 second on and 1 second off;
- Red led flashing with the same frequency of the buzzer.

The inlet has a recognition filter both upwards and downwards of 3 seconds for discriminating false contacts and not desired level alarm signals.

During the level alarm, the pump continues rotating with the set speed.

To exit from this condition, the chemical product to be dosed must be restored.

In priming mode, the level alarm is not indicated.

MOTOR ALARM

In case an excessive absorption of the motor occur due to malfunctions, the pump carries out three attempts of activation of the motor, after which the alarm is triggered and signalled by the pump in the following way:

- Acoustic signal through the buzzer (if installed on the pump), with a frequency of 1 second on and 1 second off;
- Red led flashing with the same frequency of the buzzer.

During the motor alarm, the pump clearly stops.

To exit from this condition, switch off and on the pump by using its switch or by acting on the power supply.

SWITCH ALARM

If the switch is left on the OFF position, after 10 minutes the switch alarm is activated and signalled by the pump in the following way:

- Acoustic signal through the buzzer (if installed on the pump), with a frequency of 2 seconds on and 2 seconds off;
- Red led flashing with the same frequency of the buzzer.

During the motor alarm, the pump clearly stops.

To exit from this condition, switch off and on the pump by using its switch or by acting on the power supply.

MAINTENANCE (see fig. 3)

- Periodically verify the level of the tank containing the chemical product to be dosed, in order to avoid the pump running in vain.
- Verify the foot strainer and clean it periodically from any residuals of crystallised product or accumulated dirt.
- Ensure there are no impurities in the suction and delivery tubes, because they may damage the peristaltic tube and, at the same time, cause anomalies in the capacity.

- Periodically verify the operation of the pump and the status of the peristaltic tube, especially for very aggressive chemical products.

PROVIDED KIT OF ACCESSORIES

Pumps for detergent

- PVC suction and delivery tubes (4 m.)
- Foot strainer
- Injection valve
- Wall fixing bracket

Note on environmental protection



After the implementation of the European Directive 2002/96/EU in the national legal system, the following applies:

Electrical and electronic devices may not be disposed of with domestic waste. Consumers are obliged by law to return electrical and electronic devices at the end of their service lives to the public collecting points set up for this purpose. Details to this are defined by the national law of the respective country.

This symbol on the product, the instruction manual or the package indicates that the product is subject to these regulations. By recycling, reusing the material or other forms of utilizing old devices, you are making an important contribution to protecting our environment.

FIGURE / FIGURE / FIGURE

Figura 1 / Figure 1 / Figure 1

Filtro di fondo
Foot strainer
Filtre inférieur

Valvola di non ritorno
Check valve
Clapet anti-retour



Figura 2 / Figure 2 / Figure 2

Rif.	Descrizione	Ref.	Description
A	Led bicolore	A	Two-coloured led
B	Potenziometro	B	Potentiometer
C	Porta rullini	C	Roll holders
D	Tubo peristaltico	D	Peristaltic tube
E	Raccordo di aspirazione	E	Suction fitting
F	Cavo di alimentazione 2x0,75mm ² (2 m.)	F	Power cable 2x0.75mm ² (2 m.)
G	Raccordo di mandata	G	Delivery fitting



Figura 3 / Figure 3 / Figure 3

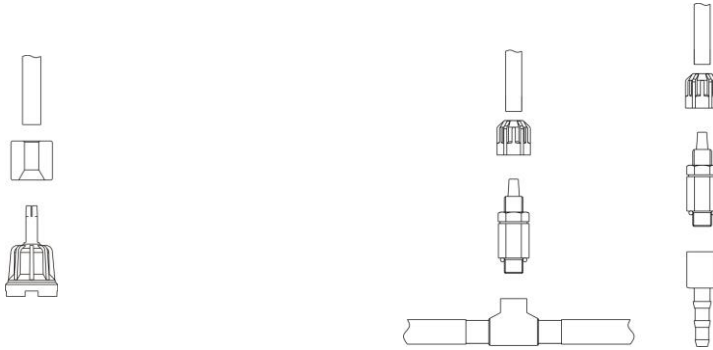

Rimozione del tubo peristaltico / Removal of the peristaltic tube / Retrait du tube

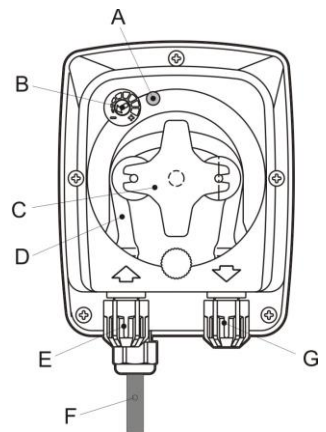
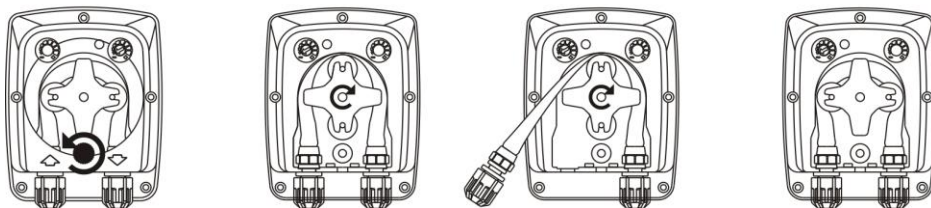
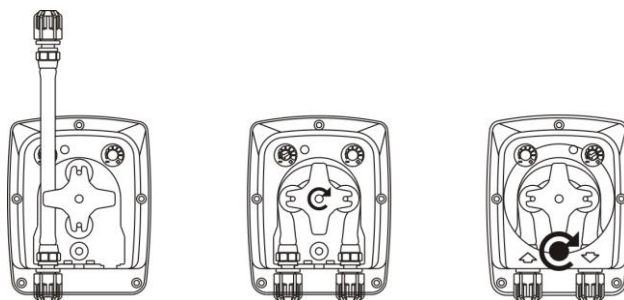

Riposizionamento del tubo / Repositioning the peristaltic tube / Repositionnement du tube

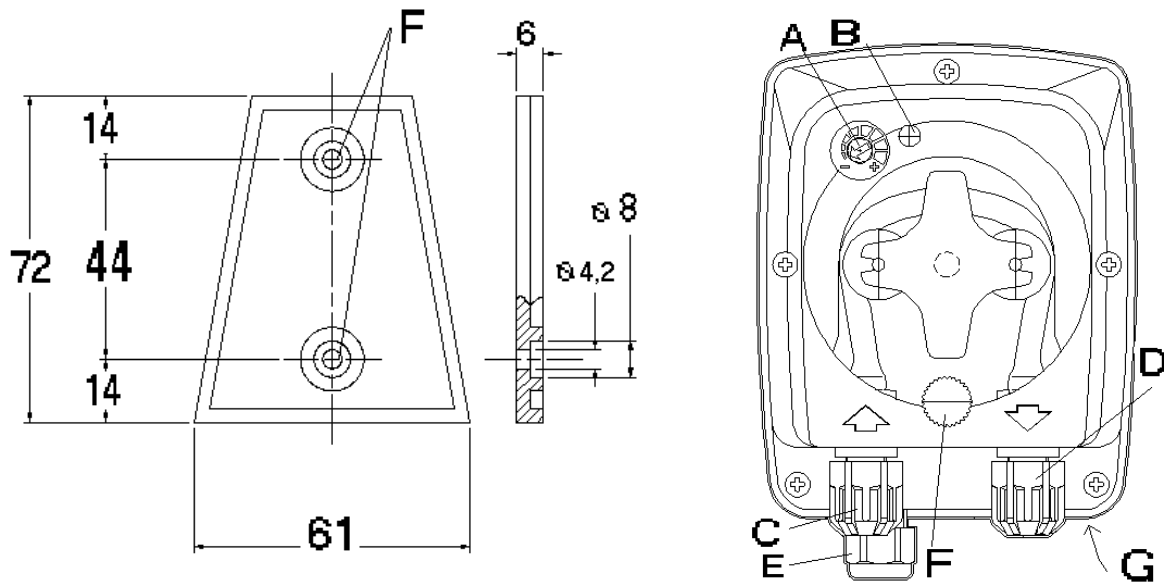

Staffa di fissaggio / wall fixing braket / support de fixation

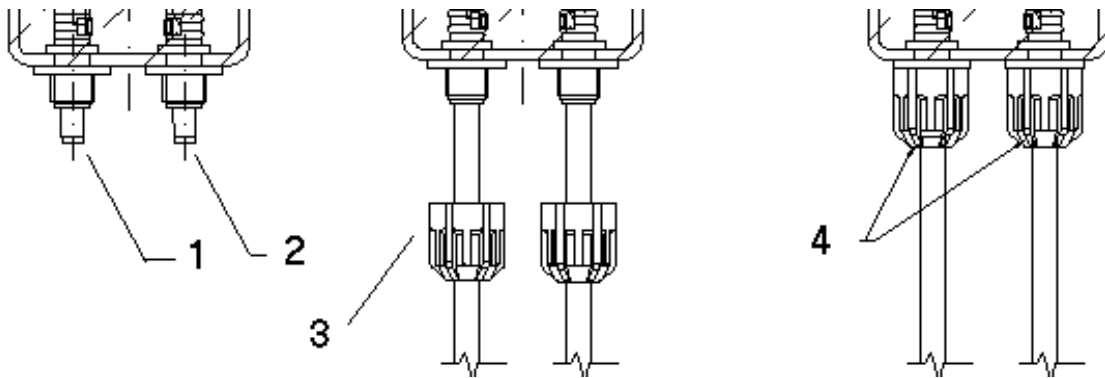

Montaggio tubi / tube mounting / assemblage de tuyaux

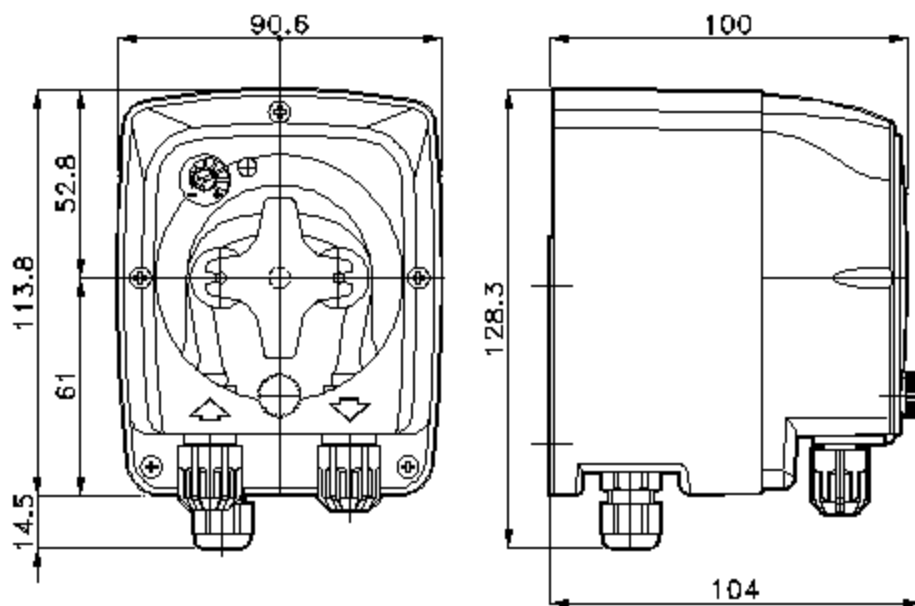

Ingombri / Measurements / mesures

PERISTALTICA TEC

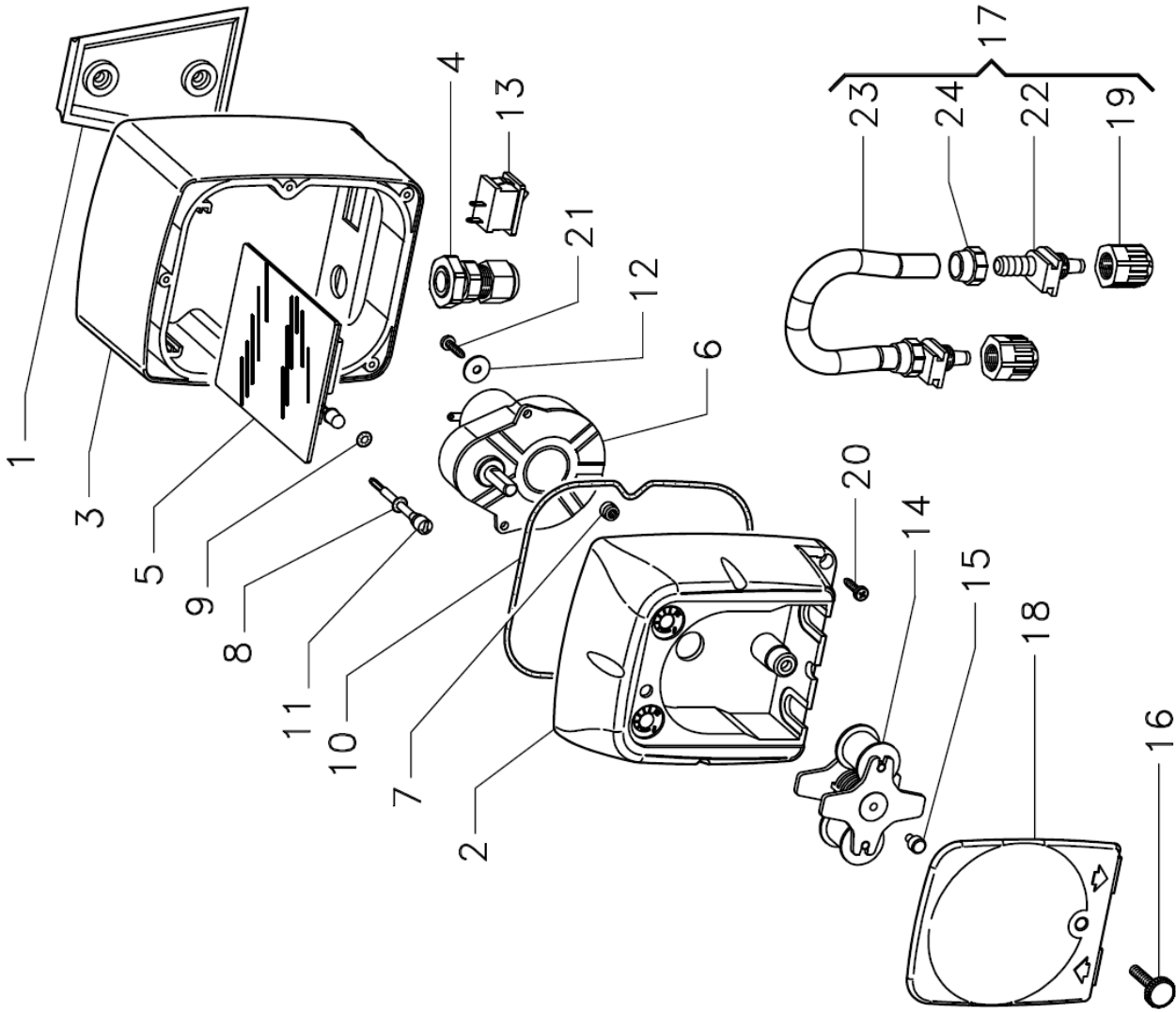

Pos.	Codice	Descrizione	Quantità
1	ADSP8000025	STAFFA DI FISSAGGIO PER-R NERO PP	1
2	ADSP8000084G	CASSA POSTERIORE TEC PP GRIGIA RAL 90687	1
3	ADSP8000094G	CASSA ANTERIORE TEC GRIGIA RAL 90687 (VN)	1
4	ADSP6000424	PRESSACAVO PASSO PG7 - 1900.07 - NERO	1
5	ADSP8000083T	SKD TEC 85-265V - SKD EL230 -	1
	ADSP8000083L	SKD TEC 85-265V + LIVELLO - SKD EL230 -	
	ADSP8000084L	SKD TEC 24VAC + LIVELLO - SKD EL231 -	
6	ADSP8000254	MOTORE RAP 225 24VDC PER-R	1
7	ADSP8000255	MOTORE RAP 125 24VDC PER-R	1
8	ADSP5007072	OR "R1" NBR - 2.80X1.90	1
9	ADSP5007013	OR - RIF. 2015 - DUTRAL	1
10	ADSP5007074	OR - RIF. 2412 - NBR	1
11	ADSP8000095	PERNO REGOLAZIONE PERISTALTICA TEC ROSSO	1
12	ADSP6000469	RONDELLA PIANA FASCIA LARGA D. 3 x 9 - DIN 9021 INOX A2	2
13	ADSP6000685	INTERRUTTORE ON/OFF/PAUSA 3A 250V TIPO A BILICO	1
14	ADSP8000023A	PORTA RULLINI COMPLETO PER-R 1-3 TYGON	1
	ADSP8000023B	PORTA RULLINI COMPLETO PER-R 4/6-1	
15	ADSP8000028	PERNO GUIDA PORTARULLINO PER-R	1
16	ADSP8000029	MANOPOLA FISSAGGIO COPERCHIO TRASPARENTE TEC	1
17	ADSP8000128	TUBO SILICONE 3X7 PER-R INCOMPLETO	1
	ADSP8000112	TUBO TYGON PER-R INCOMPLETO	
	ADSP8000138	TUBO PHARMED PER-R INCOMPLETO	
18	ADSP8000081	COPERCHIO FRONTALE TRASPARENTE TEC FUME	1
19	ADSP5004001E	GHIERA FISSA TUBO PP NERA 1/8" 4X6 STD	2
20	ADSP6000714	VITE M 2,9 X 13 UNI 6954 (TCTC) INOX A2	5
21	ADSP6000749	VITE M 2,9 X 9,5 UNI 6954 (AF-TCTC) INOX A2	2

20-05-2011