

Electric submersible pumps for drainage «Derby Ex» series



Copy reserved for:

- User



**Documento di
costruzione**

Eventuali modifiche devono essere approvate
dalla "Persona Autorizzata EX - progettazione"

Correlato al certificato di esame UE del tipo **CESI 07 ATEX 055X** documento listato n° **2006/01-03_00-04-EX IU** rev. **4**

INDEX



(translation of the official version)

1. INTRODUCTION	
1.1 Scope.....	pag. 3
1.2 Explanation of symbols.....	pag. 3
1.3 General warnings.....	pag. 4
1.4 Residual risks.....	pag. 4
2. IDENTIFICATION	
2.1 Product brand and type designation.....	pag. 4
2.2 Document edition.....	pag. 4
2.3 Manufacturer name and address.....	pag. 4
2.4 Declaration of conformity.....	pag. 5
3. SPECIFICATION OF THE PRODUCT	
3.1 General functions and range of applications, intended use.....	pag. 6
3.2 Dimensions and weights (for transport purpose).....	pag. 6
3.3 Technical data.....	pag. 6
3.4 Emission of noise.....	pag. 7
3.5 IP code, clear text	pag. 7
3.6 Environmental conditions and limits for operating and storage.....	pag. 7
3.7 Label position and information.....	pag. 8
4. PREPARING THE PRODUCT FOR USE	
4.1 Transport and storage.....	pag. 9
4.2 Handling.....	pag. 9
4.3 Safety precautions before use.....	pag. 9
4.4 Unpacking.....	pag. 9
4.5 Safety disposing of packaging material.....	pag. 10
4.6 Preparatory work before installation.....	pag. 10
4.7 Installation and assembly.....	pag. 10
4.8 Hydraulic connection.....	pag. 11
4.9 Electrical connection.....	pag. 11
5. OPERATING INSTRUCTIONS	
5.1 Safe operation/functioning.....	pag. 12
5.2 Normal functioning - starting/stop of electric pump.....	pag. 12
5.3 Normal function (manual, automated operation).....	pag. 12
5.4 Exceptional functions/situations.....	pag. 13
5.5 Personal protective equipment (PPE).....	pag. 13
5.6 Optional modules, extras.....	pag. 13
6. MAINTAINING AND CLEANING	
6.1 Safety precautions.....	pag. 13
6.2 Ordinary maintenance and cleaning.....	pag. 13
6.3 Planned maintenance.....	pag. 14
6.4 Authorized maintenance list.....	pag. 14
6.5 Trouble-shooting and fault diagnosis.....	pag. 14
7. LIST OF SPARE PARTS AND CONSUMABLES	pag. 15
8. TAKING PRODUCT OUT OF OPERATION	
8.1 Uninstalling.....	pag. 15
8.2 Scrapping.....	pag. 15
9. GUARANTEE	pag. 16

0. INDEX AND DESCRIPTION OF MODIFICATIONS

No revision	date	description of modifications
0	2008.09.12	first issue
1	2013.07.08	regulations revision
2	2017.03.13	regulations revision
3	2017.10.18	regulations revision
4	2019.10.31	regulations revision
5	2021.10.21	regulations revision

1. INTRODUCTION

1.1 Scope

This handbook has been written by the manufacturer and is an integral part of the equipment. This handbook defines the scope for which the equipment has been designed and manufactured and contains all the information necessary in order to guarantee its correct use.

Following this handbook will ensure personal safety and the longevity of the equipment.

The information in the manual covers the following areas:

- transport, handling, unpacking;
- preparation of the site;
- installation;
- use;
- maintenance.

This handbook must be stored carefully and retained at all times for future references. It must be protected from humidity, sunlight and all can damage it.

For quick searching, please see index on previous pages.

Warning symbols have been used to illustrate important parts of the text.

1.2 Explanation of symbols

The following symbols indicate the potential risk arising from ignoring the warnings to which they have been applied as shown below.



General danger

this indicates that the lack of observation of the instructions risks harm to persons, animals and other items.



Danger - voltage, risk of electric shocks

this indicates that a lack of observation of the instructions risks electric shocks



Danger – hot surface

this indicates that a lack of observation of the instructions risks burns.



Danger – moving parts

this indicates that a lack of observation of the instructions risks harm to persons. In this instance immediately disconnect the pump from the electrical mains



Danger – manual handling

this indicates that a lack of observation of the instructions risks back injury



Mandatory - reading of the handbook

The user is required to read the handbook (“instructions for use”) before installing the equipment.



Obligation – manual handling of equipment with two persons

this indicates that two people should handle the equipment.



Obligation - handling of the object with mechanical means

this indicates that the equipment should be handled by mechanical means.



Recycling

this indicates that the materials can be recycled according to local regulations



Waste management of the electrical equipment

this indicates that the materials must be disposed of in accordance with local regulations



Important information

this indicates that failing to observe the instructions risks damage to the equipment / system



Useful and/or necessary information to comply with Directive 2014/34/UE “ATEX 114” annex II

1.3 General warnings

The manufacturer declines all responsibility for damages caused to the electrical pump or the things in the following cases:

- improper use;
- employment of unauthorised personnel;
- incorrect assembly and installation;
- defects in the system;
- unauthorised modification or operation of the electric pump;
- use of non original spare parts;
- non-compliance with the rules outlined in this handbook;
- exceptional events.

Any operation carried out that is not outlined in this handbook or authorized by the manufacturer invalidates the guarantee, and is entirely the responsibility of the person performing the operation.



The electrical pump cannot be used in order to provide potable water and/or liquids.



The electrical pump cannot be used in tanks where persons or animals have contact with water/pumped liquid.

1.4 Residual risks

The equipment has been designed and manufactured according to the standards mentioned in following paragraph "2.4 - declaration of conformity".

The application of these standards has helped to reduce the risks inherent to the type of equipment to a level deemed acceptable. So, following the residual risks are indicated to which the user must take in to account.



Danger - voltage, risk of electric shock.



The pump or motor may be hot when running. For maintenance, switch off the electrical current and allow to cool before directly contacting with the body.



Not following the instructions risks personal injury.



Not following the instructions risks damage to the back.



Not following the instructions for selection, installation, inspection and maintenance of the equipment in hazardous areas increases the risk of explosion.

2. IDENTIFICATION

2.1 Product brand and type designation



Drainage centrifugal electric submersible pumps, "Derby Ex" series

Derby = it indicates the series name of the electric pump

EX = it indicates the conformity to Directive 2014/34/UE "ATEX 114"

nnn = it indicates the power of the electric pump

i.e: Derby Ex 200

2.2 Editing of document

This handbook is identified in following way

Identification	Revision	Date
DERBY EX IU	5	October 2021

2.3 Product brand and type designation

Officine di Trevi S.a.s.

S.S. n° 3 "Flaminia", km 145

I- 06039 Trevi (PG)

Italia

Tel.: 0742 381616

Fax: 0742 78792

<http://www.officineditrevi.com>

info@officineditrevi.com



The manufacturer works with a Quality Management System conforms to ISO 9001:2015 standard, certified by accredited body IMQ/CSQ with no. 9105.OFTR.

2.4 Declaration of conformity

We Officine di Trevi declare under our exclusive responsibility that the products:

**drainage electric submersible pumps
Derby Ex 50, series n. 1212**

to which this declaration refers, satisfies Essential Health and Safety Requirements (EHSR) applicable to themselves, defined by following Directives and successive integrations and/or modifications:

- 1 - Directive 2014/30/UE: annex III;
- 2 - Directive 2006/42/UE: annex I;
- 3 - Directive 2014/34/UE: annex II.

The satisfaction of above mentioned Requirements (EHSR) has been assured by applying the following standards:

1) Directive 2014/30/UE – Electromagnetic compatibility

- EN IEC 61000-6-1:2019-02 “Electromagnetic compatibility (EMC) - Part 6-1: Generic standards - Immunity standard for residential, commercial and light-industrial environments”.
- EN IEC 61000-6-2:2019-02 “Electromagnetic compatibility (EMC) - Part 6-2: Generic standards - Immunity standard for industrial environments”.
- EN IEC 61000-6-3:2021-03 “Electromagnetic compatibility (EMC) - Part 6-3: Generic standards - Emission standard for equipment in residential environments”.
- EN IEC 61000-6-4:2019-09 “Electromagnetic compatibility (EMC) Part 6-4: Generic standards – Emission standard for industrial environments”.

2) Directive 2006/42/UE - Machinery

- EN ISO 12100:2010-11 “Safety of machinery — General principles for design — Risk assessment and risk reduction”.
- EN 60204-1:2018-09 “Safety of machinery - Electrical equipment of machines - Part 1: General requirements”.^[1]
- EN ISO 9906:2012-05 “Rotodynamic pumps - Hydraulic performance acceptance tests - Grades 1, 2 and 3”

3) Directive 2014/34/UE - Equipment or protective system intended for use in potentially explosive atmospheres

- EN IEC 60079-0:2018-08 “Explosive atmospheres - Part 0: Equipment - General requirements”.
- EN 60079-6:2015-12 “Explosive atmospheres - Part 6: Equipment protection by oil immersion «o»”.^[2]
- EN 60079-7:2015-12+A1:2018-01 “Explosive atmospheres - Part 7: Equipment protection by increased safety «e»”.^[3]
- EN 60079-18:2015-04 + A1:2017-12 + AC:2018-09 “Explosive atmospheres - Part 18: Equipment protection by encapsulation “m”.
- EN ISO 80079-36:2016-04 +AC 2019-12 “Explosive atmospheres - Part 36: Non-electrical equipment for explosive atmospheres - Basic method and requirements”.
- EN ISO 80079-37:2016-04 “Explosive atmospheres - Part 37: Non-electrical equipment for explosive atmospheres - Non-electrical type of protection constructional safety “c”, control of ignition sources “b”, liquid immersion “k”.

According to Directive 2014/34/UE, above mentioned equipment is subject, relating to design aspects, of *UE-type examination certificate* (module B – annex III):

CESI 07 ATEX 055X

issued by Notified Body n. 0722

According to the same Directive, but relating to production aspects, above mentioned equipment is *products quality assurance notification* (module E – annex VII) issued by the same Notified Body:

CESI 07 ATEX 065Q

According to other Directives, above mentioned equipment is subject, relating to both the design and production aspects of *internal control production* (module A):

F.T. 2006/01 DERBY 01.02

Trevi, 06th September 2018

Signed for and on behalf of Officine di Trevi sas
Andrea FIORETTI
legal representative



^[1] limited to single-phase versions
^[2] partial conformity
^[3] partial conformity

3. SPECIFICATION OF PRODUCT

3.1 General functions and range of applications, intended use

The drainage electric submersible pumps “Derby Ex” series are electrical pumps single-impeller with vertical axis.

The drainage electric submersible pumps “Derby Ex” series can be used for the following purposes:

- emptying rainwater wells collection and infiltration;
- draining of flooded areas;
- raising of water from deep wells, bathtubs and tanks of first collection;
- waterworks of raising for industrial uses;
- sawage system and/or cesspool.

The liquids handled can contain solid particles small and average dimension (maximum 10 mm) and/or filamentous particles.

The drainage electric submersible pumps “Derby Ex” series can be used with liquids having from Ph 6 to Ph 14. Moreover they introduce one good resistance to the corrosion with chloride concentration in the liquid from Ph 11 to Ph 14.

The drainage electric submersible pumps “Derby Ex” series are intended for use on the surface (group II), in areas in which, during the normal activities, explosive atmosphere caused by gases, vapours, mists (G) are likely to occur (category 2).

 The drainage electric submersible pump “Derby Ex” series has been designed to be capable of functioning in conformity with the operational parameters established by Officine di Trevi sas and of ensuring a high level of protection.

The composed type of protection adopted ensure the requisite level of protection, even in the event of frequently occurring disturbances or electric pumps faults which normally has been taken into account during risk analysis.

3.2 Dimensions and weights (for transport purpose)

Model	Dimensions mm		Weights Kg
	H	B	
DERBY EX 50	445	230	16,7
DERBY EX 75	445	230	16,7
DERBY EX 100	475	230	18,1
DERBY EX 150	505	250	20,6
DERBY EX 200	520	250	21,8

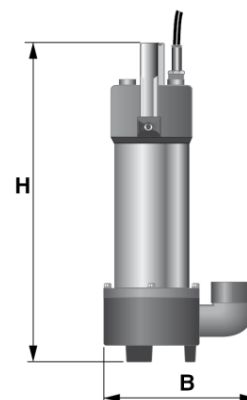

3.3 Technical data Materials

Supply cable	Flexible cable with circular section with extruded insulation with polychloroprene, EM2 type sheath; colour: black; type H07RN-F; cross-section: 1,5 mm ² x 3 + 1
Gaskets	Nitrile rubber (NBR)
Electrical connection box	Cast iron G25
Motor case	Stainless steel (X 5 CrNi18-10 “AISI 304”, otherwise identified with the type 1.4301)
Wet sleeve	//
Bearings support	Cast iron G25
External hydraulic part	Cast iron G25
Impellers/diffuser	Cast iron G25

Rated data and performances

- rated power: *see table*
- duty: S1 ^[4]
S4 ^[5] - 20 c/h ^[6]
- rated voltage: 400V₃; 230V_{1~}; ± 5%
- rated current: *see table*
- connection: star
- power factor (cos φ): *see table*
- rated frequency: 50 Hz
- rated speed: 2850 rpm
- insulation class: F (Δt F)
- maximum altitude of duty: 1000 m a.s.l.
- liquid temperature ^[7]: 20 ÷ +40°C
- liquid density: < 1200 kg/m³
- I_A/I_N: 3,8
- capacitance of electric condenser ^[8]: *see table*

tipo	potenza		corrente max		cond.	cos φ	ø mandata outlet ø	portata																
	power	max. current	[A]					flow rate																
type																								
	[hp]	[kW]	400 [V ₃]	230 [V _{1~}]	[μF]	[l/minuto]	0	50	100	150	200	250	300	350	400	450	500	550	600	650	700	750		
						[m ³ /h]	0	3	6	9	12	15	18	21	24	27	30	33	36	39	42	45		
DERBY EX 50	0,50	0,37	1,5	4,3	20	0,88	2"	8	7,3	6,5	6	5,5	4,7	3,7	3	2	1							
DERBY EX 75	0,75	0,55	1,7	5,1	20	0,88	9,5	9	8,2	7,5	6,8	6	5,2	4,2	3,2	2	1							
DERBY EX 100	1,00	0,75	2,5	7,0	25	0,85	11,5	10,9	10,2	9,6	9	8,2	7,5	6,6	5,8	5	4	3	2	1				
DERBY EX 150	1,50	1,10	3,1	10,5	35	0,90	13,1	12,5	12	11,5	10,8	10	9,1	8,2	7,3	6,5	5,5	4,3	3,2	2,1	1			
DERBY EX 200	2,00	1,50	3,8	12,5	40	0,84	15	14,5	13,9	13,2	12,5	11,9	11	10,2	9,5	8,3	7,2	6,2	5,1	4	2,4	1		

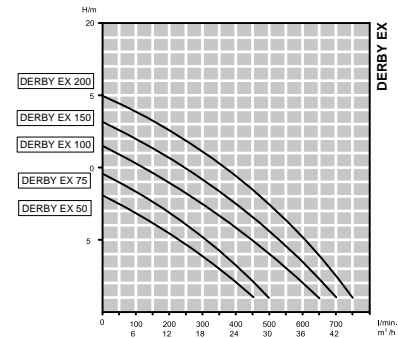

The electric and hydraulic data are concerning to tests carried out with clean liquids at 20°C.

3.4 Emission of noise

Acoustic pressure level: <70 dB(A)

3.5 IP code, clear text

Degree of protection: IP68

→first number – against access to hazardous parts and against entrance of solid foreign objects

Symbology	no.	Denomination	Description
	6	Persons	Protected against access to hazardous parts with a wire The access probe of 1,0 mm shall not penetrate
		Things	Dust-tight No entrance of dust

→second number – against water

Symbology	no.	Denomination	Description
	8	Protected against the effects of continuous immersion in water	Entrance of water in quantities causing harmful effects shall not be possible when the machine is continuously immersed in water under conditions which shall be agreed between manufacturer and user, but which are more severe than for number 7. - depth: 15 m - permanently: ∞ h

3.6 Environmental conditions and limits for operation and storage

- The electric pump must never be allowed to run dry.
- The minimum immersion level indicated must always be respected.
- The operation position is vertical.
- The tank must be free from ice.

For storage conditions see following par.4.1 “Transport and storage”.

^[4] continuous working duty at constant load
^[5] intermittent periodic duty with start
^[6] equally supplied
^[7] in case of single-phase motor
^[8] when the pumped liquid has a solidification temperature above -20°C, this new value is considered as a lower limit

3.7 Label position and information

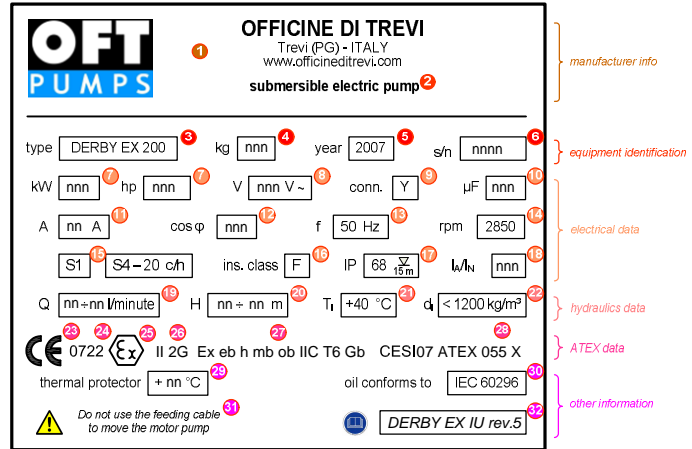
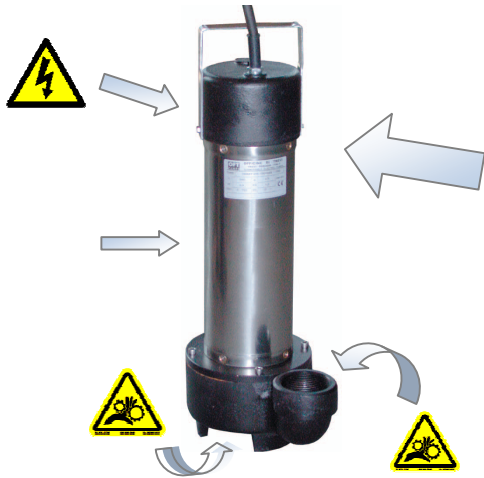

1	Brand, name and address of the manufacturer	<p>ATEX marking – type of protection</p> <p>Ex: Protection against explosions.</p> <p>eb: Type of protection applied to electrical motor – increased safety “e”, level “b” – type of protection applied to electrical apparatus in which additional measures are applied so as to give increased safety against the possibility to excessive temperature and of the occurrence of ark and sparks in normal service or under specified abnormal conditions.</p> <p>h: Type of protection applied to hydraulic part – constructional safety “k” – ignition protection where constructional measures are applied so as to protect against the possibility of ignition from hot surfaces, sparks and adiabatic compression generated by moving parts</p> <p>mb: Type of protection applied to connection facility to external circuits – encapsulation “m”, level “b” – type of protection whereby parts that are capable of igniting an explosive atmosphere by either sparking or heating are fully enclosed in a compound or in such a way as to avoid ignition of a dust layer or explosive atmosphere under operating or installation conditions</p> <p>ob: Type of protection applied to electrical motor – liquid immersion “o”, level “b” – type of protection in which the electrical equipment or parts of the electrical equipment are immersed in a protective liquid in such a way that an explosive gas atmosphere which may be above the liquid or outside the enclosure cannot be ignited.</p> <p>IIC: subgroup of gas: equipment compatible to be installed with all combustible gas</p> <p>T6: class temperature - maximum temperature of the equipment 85°C. When the mark is T5 the maximum temperature of the machine is 100°C</p> <p>Gb: installed in potentially explosive atmospheres with combustible gas - level b</p>	
2	Equipment identification		
3	Equipment type designation by manufacturer		
4	Weight		
5	Manufacturing year		
6	Serial number		
7	Supplied power		
8	Supply voltage		
9	Phases connection		
10	Capacitance of electric condenser (only for single-phase equipment)		
11	Supply current		
12	Power of factor		
13	Supply frequency		
14	Rotation speed		
15	Duty		
16	Insulation class		
17	Degree of protection		
18	Ratio between initial starting current I_A and rated current I_N		
19	Delivery		
20	Head		
21	Maximum temperature of immersion liquid		
22	Maximum density of immersion liquid		
23	Graphic symbol of CE conformity marking		
24	Identify number of Notified Body responsible for production control on "ATEX" equipment		
25	Distinctive community mark specific of explosion protect		
26	<p>ATEX marking:</p> <p>II: group of apparatus - equipment suitable to be installed in surface places</p> <p>2G: category - equipment compatible to be installed in potentially explosive atmospheres with gas, steams and vapors (area 1); this equipment is suitable for area 1 and area 2.</p>		27
			28
		29	
		30	
		31	
32	Reference to equipment use handbook		

4. PREPARING THE PRODUCTS FOR USE

4.1 Transport and storage

The drainage electric submersible pumps "Derby Ex" series are supplied in carton packs having various dimensions depending on electric pump; for the transport, packing is arranged in horizontal position.

For storage, it must be kept vertical and the packaging protected:



from rain



from sunlight

from humidity



put in vertical position

The following conditions must apply when storing electric pump



ambient temperature: from +5°C to +40°C



avoid stocking of packs

4.2 Handling

The electric pumps have different weights depending on their type.

Before handling the pack, verify the weight indicated on pack or on the electric pump label (see previous par. 3.7 - Label positions and information" )



In the event of the weight exceeding the limits prescribed, it is compulsory that the handling is carried out by two persons or through the suitable means.



It is recommend that all equipment handling is carried out with due observance of general manual handling rules.

4.3 Safety precautions before use



In the event of installation in places where stray electric currents may be present (i.e.: electric railway networks, welding areas, electric systems with high currents and radio frequencies, etc.), adequate precautions must be taken to avoid danger.

Check that the electric pump model written on the nameplate corresponds to that required and the pumped liquid is compatible with the pump construction materials.

The electric motor is cooled with oil type indicated on the plate placed on the electric pump.

Before the installation of the electric pump, check there are no oil leaks. If there are oil residue, it is necessary to contact the assistance centre.



General safety rule. The electric supply system must be isolated before working on any of the electric or mechanical parts, or on the system.

4.4 Unpacking

Transport the electric pump (in its packaging) to the point of installation.

Safely dispose of any packaging that could be dangerous to persons (nail, tapes, plastic bags, etc.)



The electric pumps are supplied in a carton pack that assures the protection during the transport.

Check that the pack has not suffered external damage during the transport.

Lay the pack on its side to unpack the pump.

Remove and lift the pump from the packaging using the pump (fig.3.1).



Never use the electric cable to lift and move the pump (fig. 3.2)

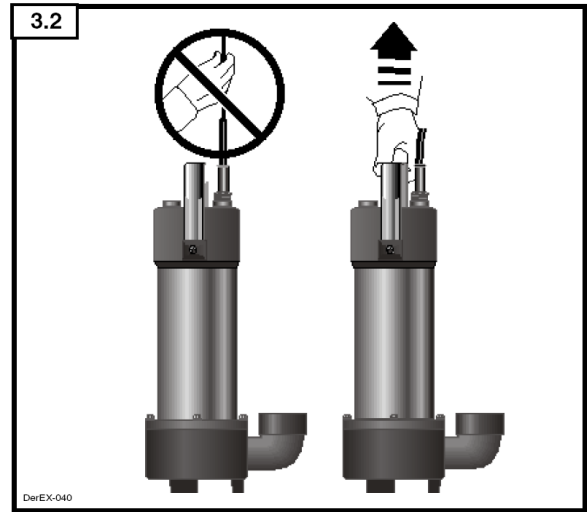
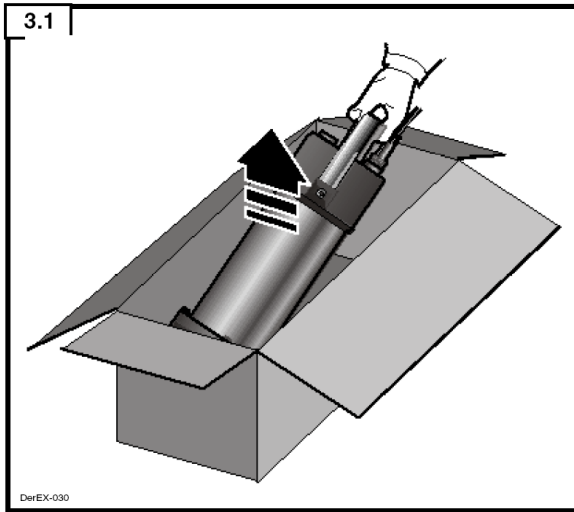

4.5. Safety disposing of packaging material



All pack materials are recyclable and can be disposed of according to local legislation.



Carton

4.6. Preparatory work before installation

Before placing the electric pump in position, clean out the area where it is to be installed.

4.7. Installing and assembling

Keep the electric pump raised from the bottom so that the sediment that will be formed after the installation does not come inhaled (fig. 3.3).

The electric pump cannot be tilted more than 5° (to right or left - fig. 3.5).

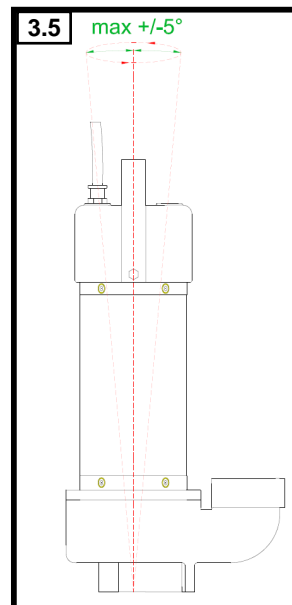
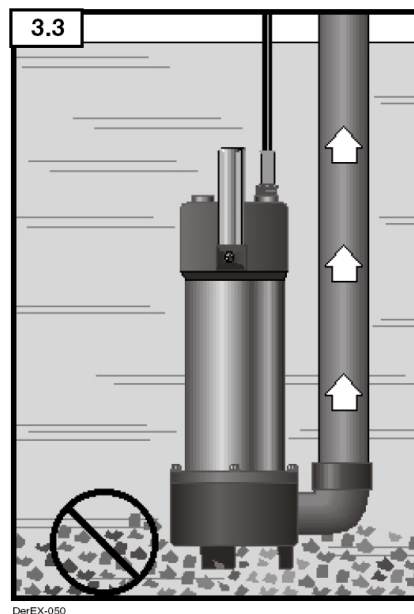

The electric pump is supplied without float switch.



If a float switch is to be installed, please refer to the regulations in force.

4.8. Hydraulic connection

 Personnel requirements: skilled pipe fitter

The hydraulic connection of the pump can be carried out with iron or plastic material either rigid or flexible. Use pipelines in suitable material to the type of liquid in contact with the electric pump.

The riser pipe should never be blocked in any way.

To ensure hydraulic and electrical integrity, the pools and/or the collection tanks must be such to avoid an excessive number of starters per hour.

To not create air aspiration, dragged by the flow turbulences, with causing operating anomalies, avoid that the fall of liquids is on the aspiration of electric pump and to make sure that the inlet aspiration is sufficiently immersed to avoid the formation of vortices.

The electric pumps can be installed both for mobile use and fixed installation. In the first case, the inlet aspiration must be connected, by a curve with rubber fitting to a flexible tube with diameter not inferior to that one of inlet aspiration of the electric pump, preferably the type "with spiral reinforcement" to have always the free passage also in correspondence of curves or changes of direction. In the second case, it is recommended to connect the electric pump to a metallic or plastic pipe and to a check valve with free passage and a on-off valve. In this case the stability of the electric pump is assured by the base and the pipe.

 Install an automatic device (i.e. flow switch) for the control of the minimum delivery capacity - 5 l/min.



4.9. Electric connection

 Personnel requirement: qualified electrician

 Personnel must be a specifically trained electrician for electric systems in areas with risk of gas explosions.

Before carrying out the connection of power cables, you must connect the earth cable as represented in the drawing below 3.6.

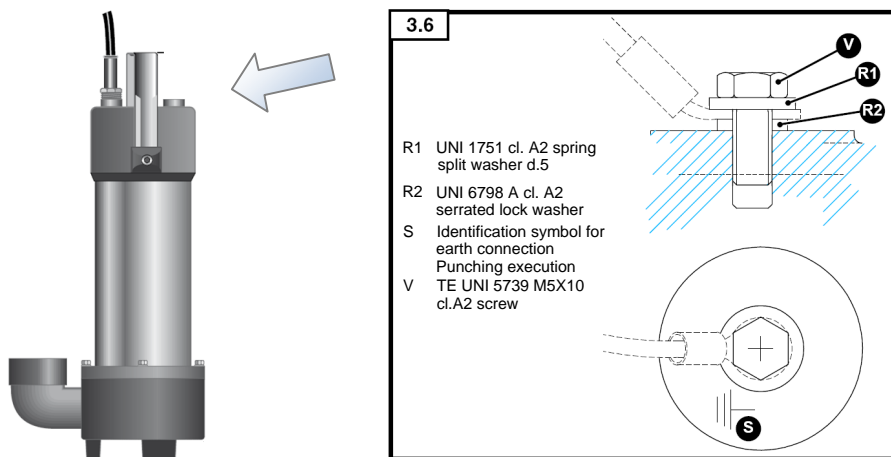

It is recommended to connect the pump to an efficient earth system according to the electric legislations

It is recommended to connect the pump to a dedicated electric supply.

the electric cable must be secured so as not to be subjected to twisting or tearing.

 The electric supply to the pump must be fitted with a residual current detector and miniature circuit-breakers of adequate sensitivity.

 The integral cable must be installed in compliance with the system standard in force.

The integral cable must be installed in compliance with the system standard in force.

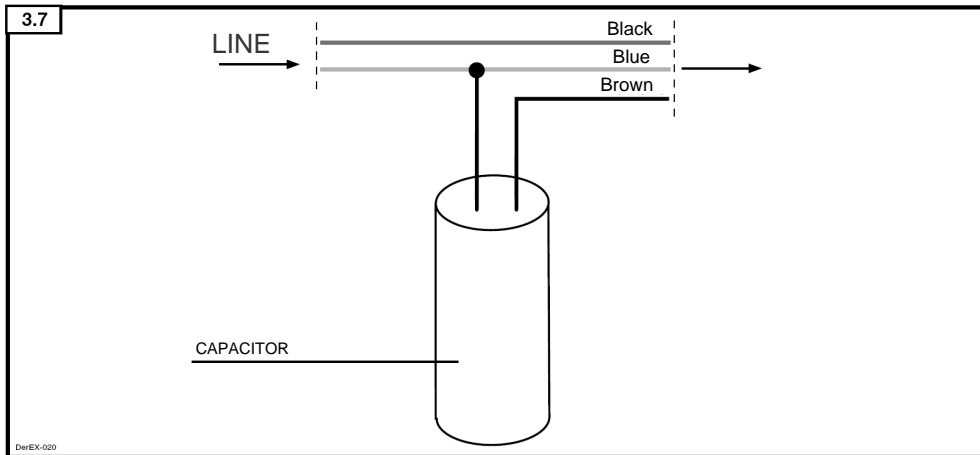

Isolate the electric power supply at the source of the system and complete the electric connection of pump.

Check and if necessary correct the direction of rotation of the electric pump (only for few seconds). Before performing a test start-up procedure, check water level in the tank; the pump must be started unless it is completely submerged in the water.



5. OPERATING INSTRUCTIONS

5.1 Safe operation

-  The drainage electric submersible pumps “Derby Ex” series must not run when dry.
-  The drainage electric submersible pumps “Derby Ex” series must be completely submersed in the liquid.
-  Check that the pumped liquid is above its solidification (freezing) temperature and between -20°C and +40°C. Vertical working position. Well or tank protected against freezing. Ensure that the electric pump is not working outside of its characteristic curve.

5.2 Normal function – starting / stop of electric pump

The starting and the stopping of the electric pump can be controlled by:

- manually, by a residual current operated and miniature circuit-breakers;
- automatically, if the electric pump is equipped with a suitable control system (responsibility of the user).

Put in position **I** (ON) the residual current operated and miniature circuit-breakers at the supply to the electric pump and wait until the water come out from the delivery pipe.

In case of abnormal operations, switch off the electric pump by putting in **0** (OFF) the residual current operated and miniature circuit-breakers and consult the following paragraph 5.4 “Exceptional functions / situations”.

5.3 Normal function (manual, automated operation)

-  It is very important that the water level never goes down (both during the operation and at rest) below the minimum level indicated in drawing.

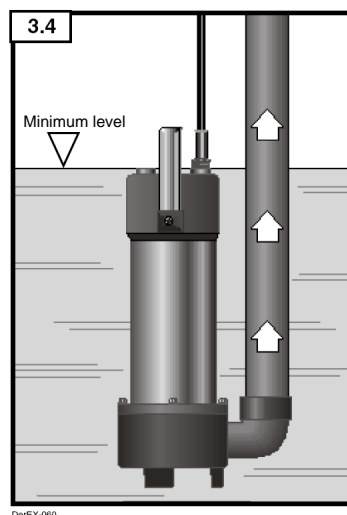

-  In order to guarantee the correct operation of the hydraulic parts of the drainage electric submersible pumps “Derby Ex” series, assured that the minimum delivery capacity is at least 5 l/min.

5.4 Exceptional functions / situations

The drainage electric submersible pumps "Derby Ex" series are equipped of 3 thermal protection devices (1 for every phase) calibrated for an automatic intervention at the temperature indicated on the plate (put on the electric pump).



The intervention of the thermal protection devices prevents the not intentional resumption of the operation.

When the thermal protection devices trip, the user must:

- disconnect the electric pump from the electrical system;
- analyse the intervention cause;
- resolve the problem that has caused it;
- restore the electric supply.

The operation of disconnecting and restoring of electric supply must be carried out from qualified staff.

5.5 Personal protective equipment (PPE)

To handle the electric pumps, especially if installed in biological or dangerous liquids, protect them with adequate clothes: safety shoes, safety glasses, protective gloves, leather apron or equivalent protection.

5.6 Optional modules, extra

Floating. The drainage electric submersible pump "Derby Ex" series work correctly also without float switch (optional)

6. MAINTAINING AND CLEANING

6.1 Safety precautions



The inspection and maintenance on the drainage electric submersible pumps "Derby Ex" series, must be carried out only from expert staff, whose training has included all the necessary instructions on the type of protection of the electric pump, on the installation methods, on the laws and standards relevant and on the general principles of the classification of the hazardous areas.



Before carrying out whichever maintenance operation, disconnect electric pump from the electric system.

Disconnect before the phases conductors, then the earth conductor (yellow/green).

Stop electric pump and to close the inlet and outlet gate valves, if present.

Extract the electric pump.

Wash copiously with water or neutralising products if required.

Clean all parts carefully.

Wait for the external temperature of the electric pump, if recently used, to reach a value below 50°C.

In case of doubts, always consult the manufacturer before proceeding to with any operation.

Since the electric pumps can be used in wells or biological tanks that may contain poisonous gas, the following precautions must be observed:



- do not work alone during any maintenance;
- air wells or tanks before installation;
- operators entering any enclosed tanks or installations must have equipment and training for working in enclosed space.

6.2 Ordinary maintenance and cleaning

The use of alcohol or solvent on the stainless steel surface and the painted parts is prohibited.

Do not use soap powders or rough cloths as the surfaces can be scratched.

Use water moistened a cloth or whichever any other product that would not damage the parts.

Do not allow to water (or any other product used) to drain inside the junction or to the electric equipment.

It is recommended to check periodically (at least 1 time per year) the following:

- integrity of the electric cable and the earth cable;
- the functionality of the residual current operated circuit-breakers;
- for the three-phase motors, to check with a clamp meter that the current absorption on the three phases is balanced and not above the values indicated on the plate;
- the tightness and the absence of accidental obstructions to the hydraulic connections;
- the cleaning of the pump installation to remove any sediments;
- the cleaning of the pump suction grille.

To verify that:

- the visible bolts and screws are tightened correctly;
- the level of noise and vibration is unchanged as regards to original levels;
- there are no corrosion marks on the electrical pump.

The replacement of the supply cable and the hydraulic parts pipelines, etc., must be executed from qualified staff.

Replacement of worn or defective components must be exclusively with original spare parts.

6.3 Planned maintenance



The planned maintenance must be executed by staff authorized by Officine di Trevi.



Every 5,000 operation hours of the electric pump:

- verify the corrected operation of the bearings;
- verify that there aren't foreign liquids inside of the oil.



Every 20,000 operation hours of the electric pump:

- replace the oil, gaskets, bearings and mechanics seals.

6.4 Authorized maintenance list



ITALY

Officine di Trevi S.a.s.

S.S. n° 3 "Flaminia", km 145



I-06039 Trevi (PG)

ITALIA

Tel: 0742 381616

Fax: 0742 78792

<http://www.officineditrevi.com>

info@officineditrevi.com

6.5 Trouble-shooting and fault diagnosis



Indications in the trouble shooting guide below do not authorise intervention where this could compromise safety.

Indications assist qualified and authorised staff in fault finding.

FAULT		POSSIBLE CAUSES		POSSIBLE REMEDIES
1	Electric pump does not start	a)	No power supply	Check that power is available on the electric connection
		b)	Impellers blocked by foreign matter	Disassemble the pump and check that the impellers turn freely
		c)	Thermal protection action	See as described in par. 5.4
2	The electric pump turns, but does not deliver water	a)	The water level is below the minimum suction level	Stop the electric pump
		b)	Low supply voltage	Increase the cross-section of the electric cable to reduce the voltage drop
		c)	Blocked suction strainer	Clean the strainer
		d)	Blocked riser pipe	Disconnect the pipe and clean it
		e)	Incorrect electrical connection	Reverse the electric cables and check the rotation direction
3	A properly calibrated thermal relay, equipped with a level sensor, trips and stops the electric pump	a)	The power supply does not conform to name plate data	Check the supply voltage
		b)	A solid body has blocked the pump	Electrically disconnect the pump and remove the solid body
		c)	The pump was pumping too hot water	Wait for the pump to cool before starting it
		d)	The pump was pumping under dry conditions	Wait a few minutes and restore the correct water level before starting the pump

7. SPARE PARTS LIST AND CONSUMABLES

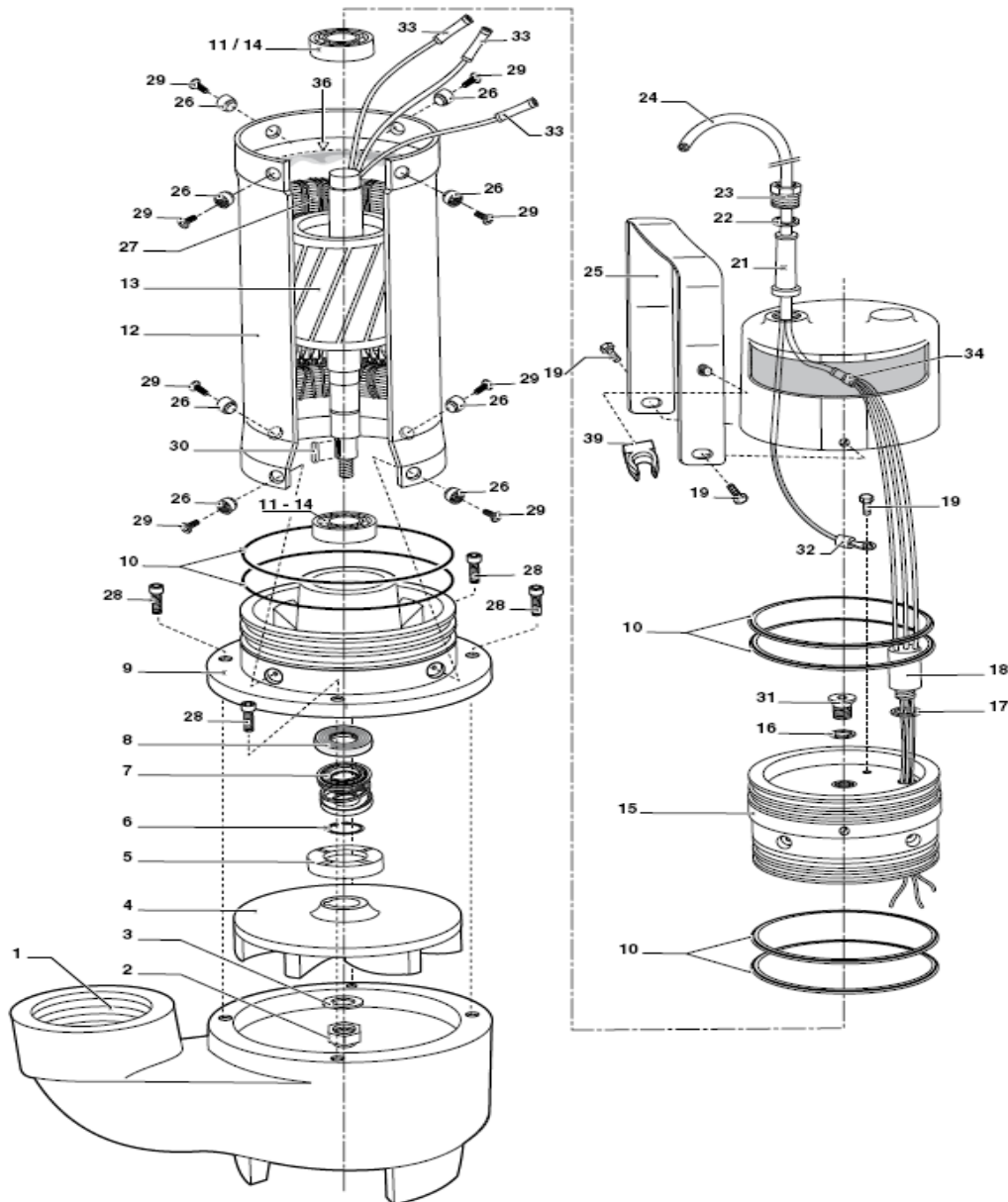

8. TAKING PRODUCT OUT OF OPERATION

8.1 Uninstalling

Personnel requirements:

- qualified pipe fitter;
- qualified electrician.

Disconnect the electricity supply to the electric pump.

Disconnect the hydraulic part, extract the electric pump from its housing and wash it with clean water.

The electric pump in this state can be stored or send back to a technical centre or to manufacturer for maintenance or send for scrap.

8.2 Scrapping



It is recommended to refer to specialised companies authorized for the scrapping of the electric pump, according to laws and standards in force.

9. GUARANTEE

- ❶ The guarantee applies only to equipment judged by the manufacturer to have faulty materials or construction.
- ❷ It does not cover parts subject to wear and breakage due to misuse and non-compliance with the rules contained in this manual.
- ❸ According to the Directive 1999/43/EC of the European Parliament and the Council, the duration of the warranty is two years from the date of delivery.
- ❹ The use of spares that are not original Officine di Trevi parts invalidates the guarantee.
- ❺ Officine di Trevi is not liable for damage or inconvenience caused by the failure to comply with the rules contained in this handbook.
- ❻ The guarantee is made ex-works; the costs for transporting the equipment under warranty from the customer to the manufacturer and vice versa are not covered by the guarantee.
- ❼ The guarantee lapses in the case of:
 - obvious tampering with the equipment;
 - any changes without prior written consent of Officine di Trevi;
 - repairs carried out by personnel that are not authorized from Officine di Trevi;
 - the identification numbers have been altered or erased or the mark Officine di Trevi has been removed.

To the extent permitted by applicable laws, liability is precluded for direct and indirect damages to persons and/or things arising from consignee's inappropriate use of the product and/or in case of non compliance with rules expressed in operating instructions.